

SOLAR ROAD STUD

MODEL CF-S-105 F

Application

The model CF-S-105 F Solar Road stud is suitable for lane to rail low and medium speed road warning.

According to the actual road conditions, a single continuous product or multiple combined products can be selected for installation on the road pavement either on one or both sides.

At night, its signaling function provides motor vehicle drivers with guidance instructions. In this way, it greatly improves road safety at night .

Technical specifications

- **Dimensions:** 129 x 117 x 77 mm.
- **Shaft dimensions:** 54mm.
- **Solar Panel:** 2V / 150 MA (Monocrystalline Silicon)
- **Ni-mh battery:** 1.2V/600MAH NI-MH Battery.
- **LED quantity:** 6 pcs.
- **LED frequency:** Flashing 90 times per minute or fixed.
- **LED colour:** Red, yellow, white, blue and green..
- **Luminous intensity:** 12000mcd-20000mcd.
- **Illumination time:** 120h after fully charged.
- **Material:** Aluminum + PC part, UV resistant.
- **Visual Distance:** >1000 meters.
- **Protection level:** IP68
- **Working temperature:** -20°C to +80 °C.
- **Weight resistance:** >20 Tons.

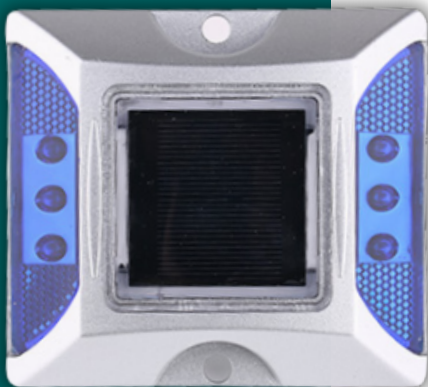

SOLAR ROAD STUD

MODEL CF-S-105 F

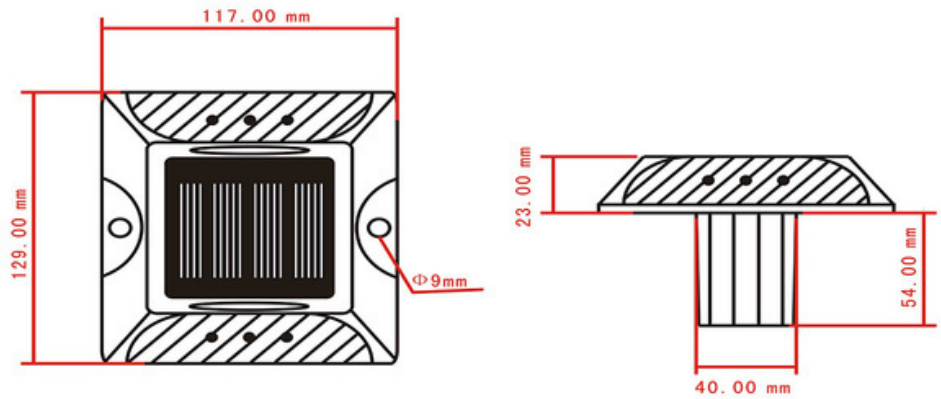

Installation

- Check if the solar panel charges and discharges normally.
- Identify the location for installation.
- Clean road surfaces.
- Drill the hole.
- Place the solar road stud in the installation position and tighten the screw.
- Set the concrete to fix the solar road stud.

